



**OVER 40 YEARS OF INNOVATION, QUALITY, SAFETY.  
IMPORTANT OWNER-OPERATOR INSTALLATION INSTRUCTIONS**

**F3008**

**Important Note:** Instructions featured online do NOT show detailed drawings or figures referenced in the instructions. Complete instructions with more detailed drawings are available in the kit upon purchase.



Version Number: 4, Date: 6/15/2022 By: KS

TECH SUPPORT (800) 246-8132

**AFTER INSTALL, PLEASE GIVE  
THIS BOOKLET TO YOUR CUSTOMER**

# Warnings

## Truck Bed and Camper Protection

Torklift **does not** recommend installing your camper on top of a plastic bed liner (or other compressible material such as foam). These materials can act as a spring, causing increased vertical truck camper movement independent of the vehicle. Plastic bed liners can slide on the truck bed surface, and the truck camper can slide on top of the bed liner. Using a plastic bed liner or similar compressible material will void your warranty and may additionally cause truck bed and/or camper damage.







Minor movement or settling can occur in some incidental harsh driving conditions (on or off-road). A rubber bed mat is recommended to protect the truck bed and camper, but is not a requirement to maintain the Torklift legendary lifetime warranty.

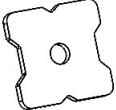

## Suspension

To significantly reduce body roll, sag and sway Torklift strongly recommends the StableLoad. Torklift International StableLoads improve safety, handling, and to help level your truck. More information can be found at ([www.Torklift.com/stableload](http://www.Torklift.com/stableload)).

If your truck is additionally equipped with suspension air bags Torklift cautions against over pressurization as this may lead to unsafe vehicle handling characteristics. We have found that airbags used in conjunction with StableLoads have allowed operators to lower air bag pressure by 50% or more. Only pressurize suspension air bags enough to level the truck.

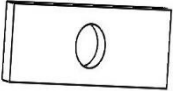
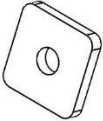
## Parts Inventory

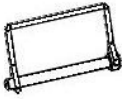
Item Image	Item Description	Item #	QTY
	Tie Down Receiver <b>(Both sides are the same)</b>	2	F3008-W1
	17 7/8" Passenger Side Straight Insert	1	TD-INS-MS-W12
	17 7/8" Driver Side Straight Insert	1	TD-INS-MS-W12
	F-250 Hitch Adapter	2	F3008-P4
	1/2"-13 x 2" Grade 8 Bolt	4	3659
	1/2" USS Flat Washer	6	6039
	1/2" Split Lock Washer	4	9302
	1/2-13 Grade 8 Nut	4	1751
	1" x 2" Plate Washer	2	10859
	2" x 2" Plate Washer	2	11403

Item Image	Item Description	Item #	QTY
	1/2" Internal external Lock washer	2	4566
	1/4" x 2 1/4" bail Pin	2	1452
	1/2" Bolt Fisher	1	3818

### Step 1:

If installing on a F-250 Super Duty, it will be necessary to install the **F-250 Hitch Adapter**. When installing on a F-350 or F-450, skip to Step 2. Insert the coiled end of the bolt fisher through the hole in the back of the Receiver in the orientation shown in figure 1.1. Place the 1/2" Internal external Lock Washer over the bolt fisher. Attach the 1/2"-13 x 2" Bolt to the bolt fisher and pull back through the hole. Install the F250 Hitch Adapter Plate with the notches in the plate facing up and down using the Hardware as shown in Figure 1.1. Torque to 40 ft-lbs.

**Important Note:** Instructions featured online do NOT show detailed drawings or figures referenced in the instructions. Complete instructions with more detailed drawings are available in the kit upon purchase.

**Step 2:**

Install one of the **Tie Down Receivers** into the hitch cross tube. Secure the Tie Down Receiver to the hitch side plate using the hardware shown in Figure 2.1.

**Important Note:** Instructions featured online do NOT show detailed drawings or figures referenced in the instructions. Complete instructions with more detailed drawings are available in the kit upon purchase.

Figure 2.1 (Passenger Side Shown with F250 Adapter)

**Step 3:**

Repeat on Driver Side of truck and torque 1/2 Grade 8 hardware to 75 ft-lbs.

## Step 4: Install Tie Down Inserts

- Insert one of the tie down inserts into each tie down receiver.
- Pin the inserts in place with a 2-1/4" bail pin. Either hole in the insert can be used. We recommend at least 1" (25mm) of clearance between the body and turnbuckles when setup.
- Place a rear insert sticker onto the face of each insert. See Figure 3.1.

**Important Note:** Instructions featured online do NOT show detailed drawings or figures referenced in the instructions. Complete instructions with more detailed drawings are available in the kit upon purchase.

Figure 3.1

*IMPORTANT NOTE: Your tie down inserts are designed to have clearance inside of the receiver. This is to account for road debris, as well as aid in installation and removal. Some rattle may be expected if the inserts are left installed while not under load from the camper.*

**Installation is complete.**

# Torklift International Limited Lifetime Warranty Information

322 Railroad Ave North, Kent, WA 98032

Torklift will require proof of purchase to register, with pictures of any defective product before issuing a replacement. Torklift will not register an product without proof of purchase, which can be faxed, scanned, emailed, mailed to the information provided below. Torklift warrants its hitches, cus hitch receivers, frame mounted tie downs, turnbuckles, and accessories (excluding wire harnesses which carry a 90 day warranty) from date of purchase against defects in material and workmanship under normal use a service for the ownership life of the original consumer purchaser. All plastic rubber, and/ or electrical components maintain a warranty of up to one year from the date of the purchase. ALL COMMERCIAL APPLICATIONS ARE WARRANTED FOR A PERIOD OF 90 DAYS FROM THE DATE OF INSTALLATION/SERVICE. Torklift will replace FREE OF CHARGE any part which proves defective in material or workmanship when presented to Torklift, TRANSPORTATION CHARGES PREPAID by purchaser, at the address above. THIS WARRANTY IS LIMITED TO DEFECTIVE PARTS REPLACEMENT ONLY. LABOR CHARGES AND/OR DAMAGE INCURRED IN INSTALLATION OR REPLACEMENT, AS WELL AS INCIDENTAL AND CONSEQUENTIAL DAMAGES CONNECTED THEREWITH ARE EXCLUDED. This warranty does not include the finish or paint on our products. Rusting, cracking or peeling of the finish is also excluded. Some states do not allow the exclusion or limitation of incidental consequential damages, so the above limitation or exclusion may not apply you. Any damage to Torklift products as a result of misuse, abuse, neglect, accident, improper installation or any use violation of instructions furnished Torklift or WHEN USED IN ANY COMMERCIAL APPLICATION WILL VOID THE WARRANTY. This warranty gives you specific legal rights, and you may also have rights which vary from state to state. With warranty serv you may be able to go to a small claims court, a state court or a federal dist court.





# **TORKLIFT™**

## **INTERNATIONAL**

**322 Railroad Ave North, Kent, WA 98032**

**Phone (800) 246-8132 Fax (253) 854-8003**

**Or visit our website: [www.TorkLift.com](http://www.TorkLift.com)**

Dear Valued Customer,

Thank you for making TorkLift your choice for truck, camper packages and accessories for your vehicle. By choosing TorkLift products, you have chosen a company that has been serving the RV industry for nearly 40 years and whose name has become synonymous with strength, quality and advanced design and installation.

Please take a few moments of your time to complete the Product Registration Warranty Card on the next page. When registering your newly purchased TorkLift products, you can be assured that your contact information is secure and that you and your product are getting the attention and respect that you deserve. Thank you again for choosing TorkLift quality products.

**Register for your lifetime warranty and receive a free Torklift International gift.**

To Fax: Send copies of the questionnaire, warranty card and receipt to  
253-854-8003

To E-mail: Send copies of the questionnaire, warranty card and receipt to  
[warranty@torklift.com](mailto:warranty@torklift.com)

To Mail: Send to Torklift International 322 Railroad Ave North, Kent, WA 98032



## OFFICIAL WARRANTY REGISTRATION CARD

322 Railroad Ave North, Kent, Wa 98032

Please fill out this form completely and return to Torklift within 30 days of purchase accompanied by a copy of your original receipt

### 1. PART(S) PURCHASED

TODAY'S DATE: \_\_\_\_\_

PART#: \_\_\_\_\_ PART#: \_\_\_\_\_

PART#: \_\_\_\_\_ PART#: \_\_\_\_\_

PART#: \_\_\_\_\_ PART#: \_\_\_\_\_

### 2. PURCHASER INFORMATION

NAME: \_\_\_\_\_

ADDRESS: \_\_\_\_\_

CITY: \_\_\_\_\_ STATE: \_\_\_\_\_ ZIP / POSTAL CODE: \_\_\_\_\_

PHONE: (\_\_\_\_) \_\_\_\_\_ - \_\_\_\_\_ EMAIL: \_\_\_\_\_

### 3. TRUCK INFORMATION

YEAR: \_\_\_\_\_ MAKE: \_\_\_\_\_

MODEL: \_\_\_\_\_ BED LENGTH: \_\_\_\_\_

### 4. CAMPER INFORMATION

YEAR: \_\_\_\_\_ MAKE: \_\_\_\_\_ MODEL: \_\_\_\_\_

### 5. DEALER INFORMATION

PURCHASED FROM: \_\_\_\_\_

ADDRESS: \_\_\_\_\_

CITY: \_\_\_\_\_ STATE: \_\_\_\_\_ ZIP / POSTAL: \_\_\_\_\_

INSTALLED BY: \_\_\_\_\_ OWNER ABOVE DEALER ANOTHER DEALER

IF ANOTHER DEALER, WHO: \_\_\_\_\_